

## Low power quad op amps

## LM124/224/324/324A/ SA534/LM2902

### DESCRIPTION

The LM124/SA534/LM2902 series consists of four independent, high-gain, internally frequency-compensated operational amplifiers designed specifically to operate from a single power supply over a wide range of voltages.

### UNIQUE FEATURES

In the linear mode, the input common-mode voltage range includes ground and the output voltage can also swing to ground, even though operated from only a single power supply voltage.

The unity gain crossover frequency and the input bias current are temperature-compensated.

### FEATURES

- Internally frequency-compensated for unity gain
- Large DC voltage gain: 100dB
- Wide bandwidth (unity gain): 1MHz (temperature-compensated)
- Wide power supply range Single supply:  $3V_{DC}$  to  $30V_{DC}$  or dual supplies:  $\pm 1.5V_{DC}$  to  $\pm 15V_{DC}$
- Very low supply current drain: essentially independent of supply voltage (1mW/op amp at  $+5V_{DC}$ )
- Low input biasing current:  $45nA_{DC}$  (temperature-compensated)
- Low input offset voltage:  $2mV_{DC}$  and offset current:  $5nA_{DC}$
- Differential input voltage range equal to the power supply voltage
- Large output voltage:  $0V_{DC}$  to  $V_{CC}-1.5V_{DC}$  swing

### ORDERING INFORMATION

DESCRIPTION	TEMPERATURE RANGE	ORDER CODE	DWG #
14-Pin Plastic Dual In-Line Package (DIP)	-55°C to +125°C	LM124N	SOT27-1
14-Pin Ceramic Dual In-Line Package (CERDIP)	-55°C to +125°C	LM124F	0581B
14-Pin Plastic Dual In-Line Package (DIP)	-25°C to +85°C	LM224N	SOT27-1
14-Pin Ceramic Dual In-Line Package (CERDIP)	-25°C to +85°C	LM224F	0581B
14-Pin Plastic Small Outline (SO) Package	-25°C to +85°C	LM224D	SOT108-1
14-Pin Plastic Dual In-Line Package (DIP)	0°C to +70°C	LM324N	SOT27-1
14-Pin Ceramic Dual In-Line Package (CERDIP)	0°C to +70°C	LM324F	0581B
14-Pin Plastic Small Outline (SO) Package	0°C to +70°C	LM324D	SOT108-1
14-Pin Plastic Dual In-Line Package (DIP)	0°C to +70°C	LM324AN	SOT27-1
14-Pin Plastic Small Outline (SO) Package	0°C to +70°C	LM324AD	SOT108-1
14-Pin Plastic Dual In-Line Package (DIP)	-40°C to +85°C	SA534N	SOT27-1
14-Pin Ceramic Dual In-Line Package (CERDIP)	-40°C to +85°C	SA534F	0581B
14-Pin Plastic Small Outline (SO) Package	-40°C to +85°C	SA534D	SOT108-1
14-Pin Plastic Small Outline (SO) Package	-40°C to +125°C	LM2902D	SOT108-1
14-Pin Plastic Dual In-Line Package (DIP)	-40°C to +125°C	LM2902N	SOT27-1

### PIN CONFIGURATION

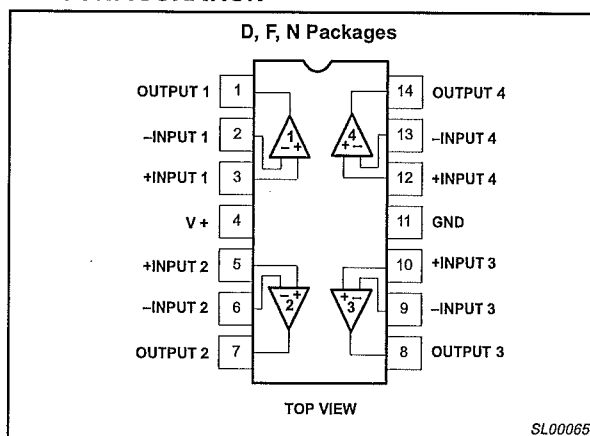

Figure 1. Pin Configuration

## Low power quad op amps

LM124/224/324/324A/  
SA534/LM2902

## ABSOLUTE MAXIMUM RATINGS

SYMBOL	PARAMETER	RATING	UNIT
$V_{CC}$	Supply voltage	32 or $\pm 16$	$V_{DC}$
$V_{IN}$	Differential input voltage	32	$V_{DC}$
$V_{IN}$	Input voltage	-0.3 to +32	$V_{DC}$
$P_D$	Maximum power dissipation, $T_A=25^\circ\text{C}$ (still-air) <sup>1</sup>		
	N package	1420	mW
	F package	1190	mW
	D package	1040	mW
	Output short-circuit to GND one amplifier <sup>2</sup> $V_{CC} < 15V_{DC}$ and $T_A=25^\circ\text{C}$	Continuous	
$I_{IN}$	Input current ( $V_{IN} < -0.3V$ ) <sup>3</sup>	50	mA
$T_A$	Operating ambient temperature range		
	LM324/A	0 to +70	$^\circ\text{C}$
	LM224	-25 to +85	$^\circ\text{C}$
	SA534	-40 to +85	$^\circ\text{C}$
	LM2902	-40 to +125	$^\circ\text{C}$
LM124	-55 to +125	$^\circ\text{C}$	
$T_{STG}$	Storage temperature range	-65 to +150	$^\circ\text{C}$
$T_{SOLD}$	Lead soldering temperature (10sec max)	300	$^\circ\text{C}$

## NOTES:

- Derate above  $25^\circ\text{C}$  at the following rates:  
F package at  $9.5\text{mW}/^\circ\text{C}$   
N package at  $11.4\text{mW}/^\circ\text{C}$   
D package at  $8.3\text{mW}/^\circ\text{C}$
- Short-circuits from the output to  $V_{CC+}$  can cause excessive heating and eventual destruction. The maximum output current is approximately 40mA, independent of the magnitude of  $V_{CC}$ . At values of supply voltage in excess of  $+15V_{DC}$  continuous short-circuits can exceed the power dissipation ratings and cause eventual destruction.
- This input current will only exist when the voltage at any of the input leads is driven negative. It is due to the collector-base junction of the input PNP transistors becoming forward biased and thereby acting as input bias clamps. In addition, there is also lateral NPN parasitic transistor action on the IC chip. This action can cause the output voltages of the op amps to go to the  $V+$  rail (or to ground for a large overdrive) during the time that the input is driven negative.

## Low power quad op amps

LM124/224/324/324A/  
SA534/LM2902

## DC ELECTRICAL CHARACTERISTICS

 $V_{CC}=5V$ ,  $T_A=25^\circ C$  unless otherwise specified.

SYMBOL	PARAMETER	TEST CONDITIONS	LM124/LM224			LM324/SA534/LM2902			UNIT
			Min	Typ	Max	Min	Typ	Max	
$V_{OS}$	Offset voltage <sup>1</sup>	$R_S=0\Omega$		$\pm 2$	$\pm 5$		$\pm 2$	$\pm 7$	mV
		$R_S=0\Omega$ , over temp.			$\pm 7$			$\pm 9$	
$\Delta V_{OS}/\Delta T$	Temperature drift	$R_S=0\Omega$ , over temp.		7			7		$\mu V/^\circ C$
$I_{BIAS}$	Input current <sup>2</sup>	$I_{IN}(+)$ or $I_{IN}(-)$		45	150		45	250	nA
		$I_{IN}(+)$ or $I_{IN}(-)$ , over temp.		40	300		40	500	
$\Delta I_{BIAS}/\Delta T$	Temperature drift	Over temp.		50			50		$\mu A/^\circ C$
$I_{OS}$	Offset current	$I_{IN}(+)-I_{IN}(-)$		$\pm 3$	$\pm 30$		$\pm 5$	$\pm 50$	nA
		$I_{IN}(+)-I_{IN}(-)$ , over temp.			$\pm 100$			$\pm 150$	
$\Delta I_{OS}/\Delta T$	Temperature drift	Over temp.		10			10		$\mu A/^\circ C$
$V_{CM}$	Common-mode voltage range <sup>3</sup>	$V_{CC}\leq 30V$	0		$V_{CC}-1.5$	0		$V_{CC}-1.5$	V
		$V_{CC}\leq 30V$ , over temp.	0		$V_{CC}-2$	0		$V_{CC}-2$	
CMRR	Common-mode rejection ratio	$V_{CC}=30V$	70	85		65	70		dB
$V_{OUT}$	Output voltage swing	$R_L=2k\Omega$ , $V_{CC}=30V$ , over temp.	26			26			V
$V_{OH}$	Output voltage high	$R_L\leq 10k\Omega$ , $V_{CC}=30V$ , over temp.	27	28		27	28		V
$V_{OL}$	Output voltage low	$R_L\leq 10k\Omega$ , over temp.		5	20		5	20	mV
$I_{CC}$	Supply current	$R_L=\infty$ , $V_{CC}=30V$ , over temp.		1.5	3		1.5	3	mA
		$R_L=\infty$ , over temp.		0.7	1.2		0.7	1.2	
$A_{VOL}$	Large-signal voltage gain	$V_{CC}=15V$ (for large $V_O$ swing), $R_L\geq 2k\Omega$	50	100		25	100		V/mV
		$V_{CC}=15V$ (for large $V_O$ swing), $R_L\geq 2k\Omega$ , over temp.	25			15			
	Amplifier-to-amplifier coupling <sup>5</sup>	$f=1kHz$ to $20kHz$ , input referred		-120			-120		dB
PSRR	Power supply rejection ratio	$R_S\leq 0\Omega$	65	100		65	100		dB
$I_{OUT}$	Output current source	$V_{IN+}=+1V$ , $V_{IN-}=0V$ , $V_{CC}=15V$	20	40		20	40		mA
		$V_{IN+}=+1V$ , $V_{IN-}=0V$ , $V_{CC}=15V$ , over temp.	10	20		10	20		
	sink	$V_{IN-}=+1V$ , $V_{IN+}=0V$ , $V_{CC}=15V$	10	20		10	20		
		$V_{IN-}=+1V$ , $V_{IN+}=0V$ , $V_{CC}=15V$ , over temp.	5	8		5	8		
		$V_{IN-}=+1V$ , $V_{IN+}=0V$ , $V_O=200mV$	12	50		12	50		$\mu A$
$I_{SC}$	Short-circuit current <sup>4</sup>		10	40	60	10	40	60	mA
GBW	Unity gain bandwidth			1			1		MHz
SR	Slew rate			0.3			0.3		$V/\mu s$
$V_{NOISE}$	Input noise voltage	$f=1kHz$		40			40		$nV/\sqrt{Hz}$
$V_{DIFF}$	Differential input voltage <sup>3</sup>				$V_{CC}$			$V_{CC}$	V

## Low power quad op amps

LM124/224/324/324A/  
SA534/LM2902**DC ELECTRICAL CHARACTERISTICS** (Continued) $V_{CC}=5V$ ,  $T_A=25^{\circ}C$  unless otherwise specified.

SYMBOL	PARAMETER	TEST CONDITIONS	LM324A			UNIT
			Min	Typ	Max	
$V_{OS}$	Offset voltage <sup>1</sup>	$R_S=0\Omega$		$\pm 2$	$\pm 3$	mV
		$R_S=0\Omega$ , over temp.			$\pm 5$	
$\Delta V_{OS}/\Delta T$	Temperature drift	$R_S=0\Omega$ , over temp.		7	30	$\mu V/^{\circ}C$
$I_{BIAS}$	Input current <sup>2</sup>	$I_{IN(+)} \text{ or } I_{IN(-)}$		45	100	nA
		$I_{IN(+)} \text{ or } I_{IN(-)}$ , over temp.		40	200	
$\Delta I_{BIAS}/\Delta T$	Temperature drift	Over temp.		50		$pA/^{\circ}C$
$I_{OS}$	Offset current	$I_{IN(+)}-I_{IN(-)}$		$\pm 5$	$\pm 30$	nA
		$I_{IN(+)}-I_{IN(-)}$ , over temp.			$\pm 75$	
$\Delta I_{OS}/\Delta T$	Temperature drift	Over temp.		10	300	$pA/^{\circ}C$
$V_{CM}$	Common-mode voltage range <sup>3</sup>	$V_{CC}\leq 30V$	0		$V_{CC}-1.5$	V
		$V_{CC}\leq 30V$ , over temp.	0		$V_{CC}-2$	V
CMRR	Common-mode rejection ratio	$V_{CC}=30V$	65	85		dB
$V_{OUT}$	Output voltage swing	$R_L=2k\Omega$ , $V_{CC}=30V$ , over temp.	26			V
$V_{OH}$	Output voltage high	$R_L\leq 10k\Omega$ , $V_{CC}=30V$ , over temp.	27	28		V
$V_{OL}$	Output voltage low	$R_L\leq 10k\Omega$ , over temp.		5	20	mV
$I_{CC}$	Supply current	$R_L=\infty$ , $V_{CC}=30V$ , over temp.		1.5	3	mA
		$R_L=\infty$ , over temp.		0.7	1.2	mA
$A_{VOL}$	Large-signal voltage gain	$V_{CC}=15V$ (for large $V_O$ swing), $R_L\geq 2k\Omega$	25	100		V/mV
		$V_{CC}=15V$ (for large $V_O$ swing), $R_L\geq 2k\Omega$ , over temp.	15			V/mV
	Amplifier-to-amplifier coupling <sup>5</sup>	$f=1kHz$ to $20kHz$ , input referred		-120		dB
PSRR	Power supply rejection ratio	$R_S=0\Omega$	65	100		dB
$I_{OUT}$	Output current source	$V_{IN+}=+1V$ , $V_{IN-}=0V$ , $V_{CC}=15V$	20	40		mA
		$V_{IN+}=+1V$ , $V_{IN-}=0V$ , $V_{CC}=15V$ , over temp.	10	20		mA
	Output current sink	$V_{IN-}=+1V$ , $V_{IN+}=0V$ , $V_{CC}=15V$	10	20		mA
		$V_{IN-}=+1V$ , $V_{IN+}=0V$ , $V_{CC}=15V$ , over temp.	5	8		mA
		$V_{IN-}=+1V$ , $V_{IN+}=0V$ , $V_O=200mV$	12	50		$\mu A$
$I_{SC}$	Short-circuit current <sup>4</sup>		10	40	60	mA
$V_{DIFF}$	Differential input voltage <sup>3</sup>				$V_{CC}$	V
GBW	Unity gain bandwidth			1		MHz
SR	Slew rate			0.3		V/ $\mu s$
$V_{NOISE}$	Input noise voltage	$f=1kHz$		40		nV/ $\sqrt{Hz}$

**NOTES:**

- $V_O = 1.4V_{DC}$ ,  $R_S=0\Omega$  with  $V_{CC}$  from 5V to 30V and over full input common-mode range ( $0V_{DC+}$  to  $V_{CC}-1.5V$ ).
- The direction of the input current is out of the IC due to the PNP input stage. This current is essentially constant, independent of the state of the output so no loading change exists on the input lines.
- The input common-mode voltage or either input signal voltage should not be allowed to go negative by more than 0.3V. The upper end of the common-mode voltage range is  $V_{CC}-1.5$ , but either or both inputs can go to  $+32V$  without damage.
- Short-circuits from the output to  $V_{CC}$  can cause excessive heating and eventual destruction. The maximum output current is approximately 40mA independent of the magnitude of  $V_{CC}$ . At values of supply voltage in excess of  $+15V_{DC}$ , continuous short-circuits can exceed the power dissipation ratings and cause eventual destruction. Destructive dissipation can result from simultaneous shorts on all amplifiers.
- Due to proximity of external components, insure that coupling is not originating via stray capacitance between these external parts. This typically can be detected as this type of coupling increases at higher frequencies.

Low power quad op amps

LM124/224/324/324A/  
SA534/LM2902

EQUIVALENT CIRCUIT

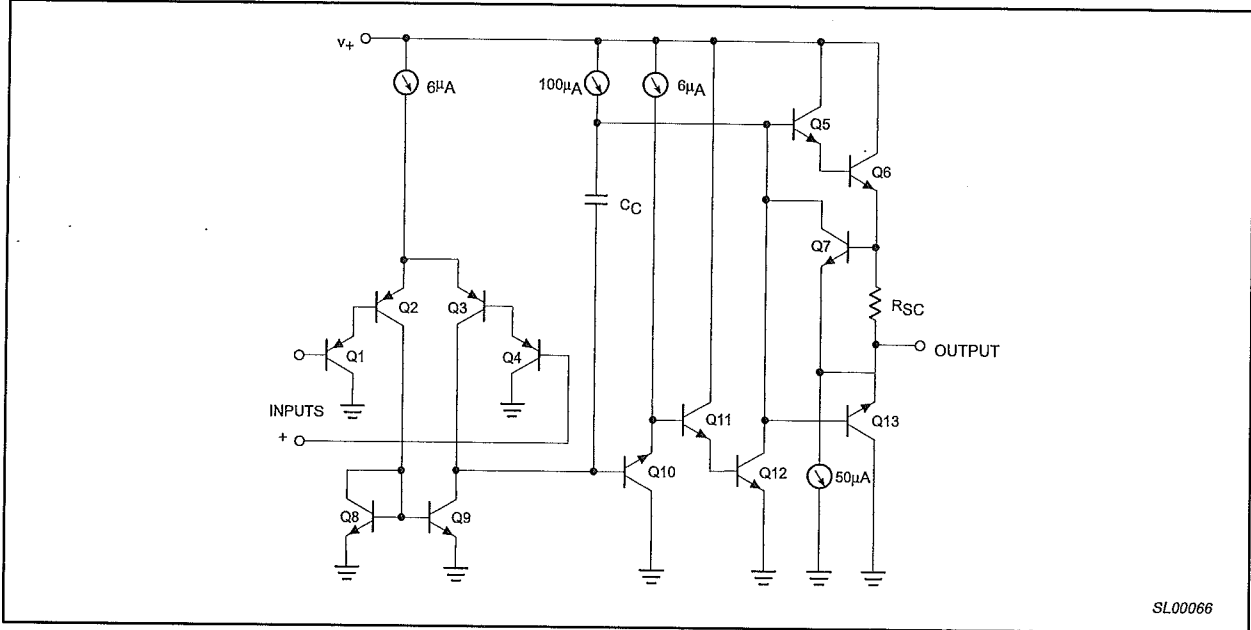

Figure 2. Equivalent Circuit

Low power quad op amps

LM124/224/324/324A/  
SA534/LM2902

TYPICAL PERFORMANCE CHARACTERISTICS

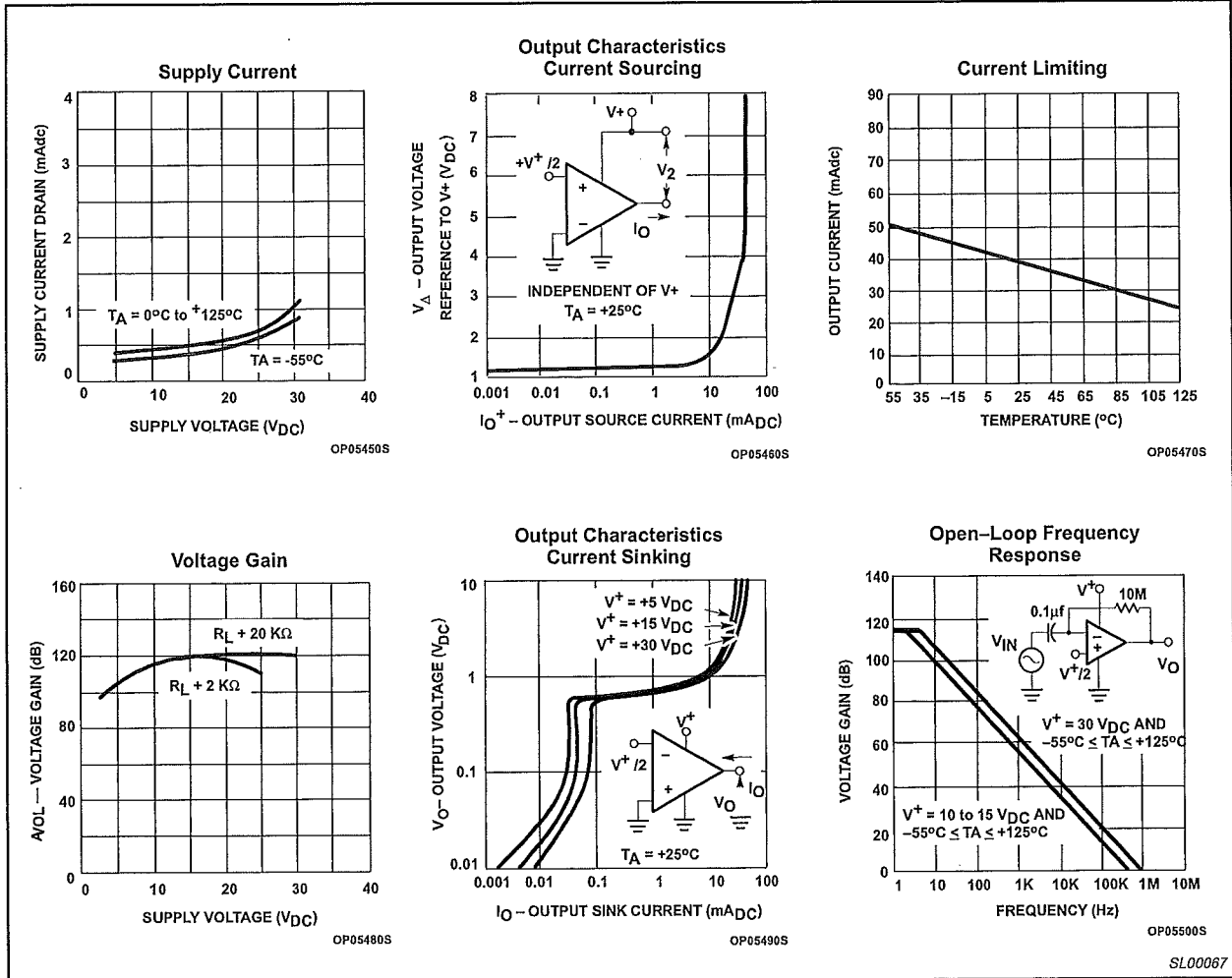

Figure 3. Typical Performance Characteristics

Low power quad op amps

LM124/224/324/324A/  
SA534/LM2902

TYPICAL PERFORMANCE CHARACTERISTICS (Continued)

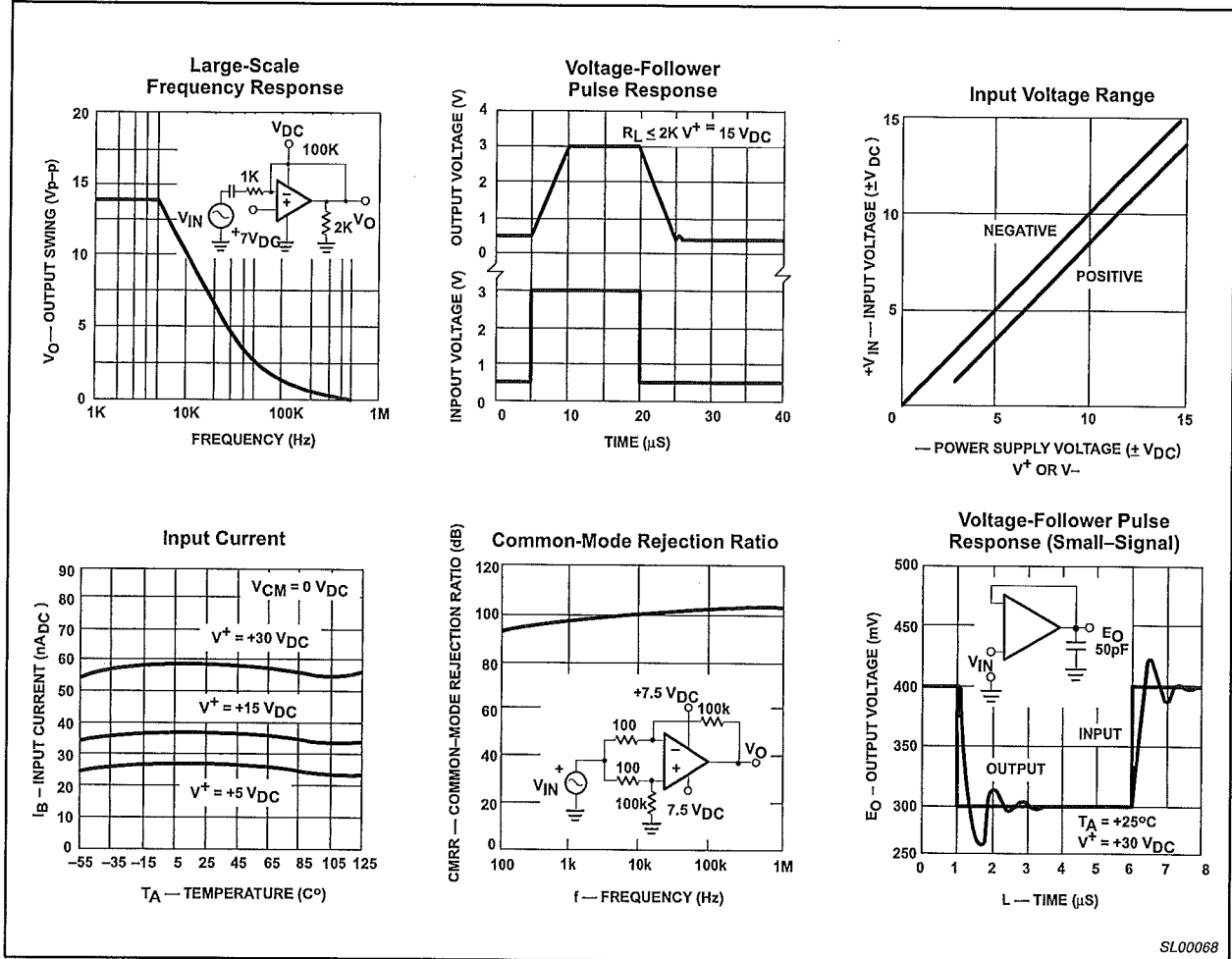

Figure 4. Typical Performance Characteristics (cont.)

TYPICAL APPLICATIONS

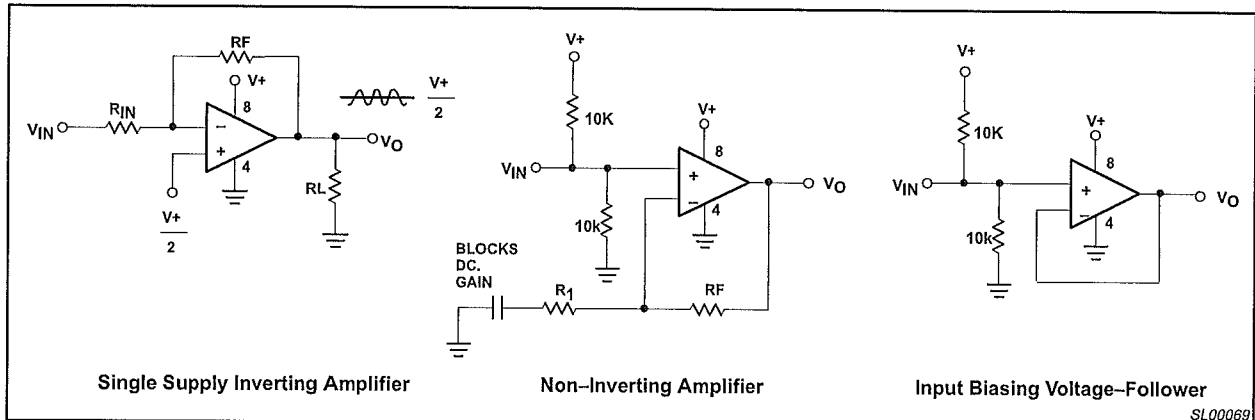

Figure 5. Typical Applications